



User Manual Installation and Product Warranty



ISO 14001:2004



MODEL
ADR75-V-ET-1

Company Profile

1874

A.O.Smith is founded in Milwaukee, Wisconsin.

1936

A.O.Smith patents the glass-lined water heater. This concept quickly became the standard of the industry, and company became one of the biggest water heater manufacturers in US.

1974

A.O.Smith's 100th anniversary. Introduction of the Conservationist® line of residential water heater.

1998

The A.O.Smith headquarter invests USD 30 million to set up A.O.Smith Water Heater Co. Ltd in China

1999

The water heaters manufactured by A.O.Smith (China) have passed the UL Certificate by Underwriter Laboratories Inc. and begun to export to US.

2001

A.O. Smith acquires State Industries, Inc., and its APCOM Inc. subsidiary, nearly doubling the size of its water heater business.

A.O.Smith announced to invest USD 20 million to increase the R&D investment and enlarge the water heater production line in China.



2006

A.O. Smith takes over GSW Inc., Canada. This makes A.O. Smith world's largest company in hot water supply.

2009

A.O.Smith enters the global water treatment industry with the creation of A.O.Smith Water Treatment Products Co., Ltd. R&D departments dedicated for water purification products set up in the Corporation Technology Center in Milwaukee, Wisconsin US and Shanghai. A.O.Smith water Treatment Products Co., Ltd has received more than 80 patents for the development of our RO water purifiers, water softeners, industrial RO water systems and other water treatment products.

A.O.Smith water treatment products exports to over 50 countries and regions of the world, including North America, Europe, Middle East, Southeast Asia.

2010

The world first patented side stream RO membrane with highest recovery rate of tap water, energy saving, environmental protection and longer filters life. A.O.Smith set up a worldwide class factory to produce water heater and water treatment products in India.

2014

A.O.Smith has founded for 140 years

Letter to Customer

Dear Esteemed Customer:

Thank you for purchasing an A. O. Smith water purifier. You now own water treatment equipment from A. O. Smith - a brand that throughout its 140-year history has brought comfort and reliability to customers in more than 50 countries in North America, Europe, the Middle East, Southeast Asia and beyond.

We firmly believe that our strictly controlled, in-house water purifier manufacturing processes offer the most reliable and effective product. With regard to materials, we exceed the strict statutory requirements in the industry by fabricating the best fittings and parts used in water treatment equipment. We guarantee the highest possible purity of water from your device by using unique, proprietary technology and by applying strict quality controls beginning with raw materials through to the finished product.

Our tagline "Innovation has a name" is reflected in A. O. Smith's commitment to continuous innovation in residential water purification manufacturing. To date we have received more than 80 patents for the development of our RO water purifiers, water softeners, industrial RO water systems and other water treatment products.

A. O. Smith is dedicated to providing healthy drinking water solutions for our customers worldwide.

Before installing and using your water purifier, please be sure to read the user manual to ensure that installation is done in a qualified and safe manner as well as to provide you with operating and maintenance tips to maximize the use of your water purifier.

If you experience any difficulty installing or using your water purifier, please contact our professional service team via our hotline for timely assistance.

Outstanding Features



Side Stream RO Membrane

The world first patented side stream RO membrane with highest recovery rate of tap water, it can reduce at least 50% of waste water vs. the traditional RO membrane, while increase 30% of pure water output.



Filter Replacement Warning

Timely remind you when filters need to replace to ensure highest pure water quality.



LED Display

Big LED display screen and icons that indicate working function and filter replacement reminder.



1:1 Pure water : Waste water



Child Lock

With child lock function to prevent children from



Max. 92°C



Min. 9°C

Contents

Safety Information	6	Maintenance & Upkeep	17
Product Introduction	9	• Filter Life	17
• Product Appearance	9	• How to Replace Filter	18
• Technical Parameters	9	• Notes	19
• Structural Drawing	10	Troubleshooting	20
• Electrical Circuit Diagram	10	Package Contents	21
• Water Flow Diagram	11	Warranty Terms & Conditions	22
• Product Introduction	11		
How to Install	14		
• Pre-Installation Preparation	14		
• Instruction for Proper Installation	14		
Adjustment Procedures	16		
Operating Instructions	17		

Safety Information

Read and follow all safety information contained in these instructions to avoid possible property damage or harm to you or others.

Ignoring the following safety precautions could result in a hazardous situation:

ⓘ WARNING: If not observed, serious injury or property damage could occur.

⚠ NOTES: If not observed, slight injury or property damage could occur.

ⓘ WARNING



Don't disassemble or modify this water purifier on your own.

Unauthorized disassembly or modification of the machine could lead to machine malfunctions or leaks.

Unplug the unit before repair, inspection, or replacement.



Electrical shock may occur if you do not unplug the unit.

Don't use a power source exceeding the machine's specified value, only use 220V AC power.



Overheating or fire may result if the power source and machine's current are incompatible.

Keep the water purifier away from high temperatures and humidity.



Electrical shock, a short circuit, fire or damage to the machine's housing may occur as a result.

Don't make the machine wet.

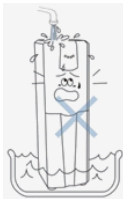

Leakage, fire, or electrical shock may occur.

Don't damage power cord or socket.



Electrical shock, a short circuit, fire may occur as a result. If power cord is damaged, it must be replaced by maintenance staff or professional technicians authorized by our company.

Keep the water purifier away from fire.



Damage to the machine's housing, even severe personal injury or property loss may occur as a result.

Don't contact power plug with wet hand.



Electrical shock may occur.

Don't put things on top of the machine.



Damage to the machine or fire may occur as a result of hindering heat dissipation .

Don't contact with corrosive material.



Corrosive material might corrode inner components. Or if some toxic substances penetrate into water purifier pipeline, pollution, water leakage, even severe personal injury and property loss may result.

Don't operate this water purifier under high water pressure conditions.



Operating under high water pressure conditions may cause the water purifier pipes to rupture, resulting in leaks, machine malfunctions, or even serious property damage. Recommended inlet pressure is 0.1MPa to 0.35MPa.

! NOTES

Do not operate the water purifier when the sewer is blocked.



Wastewater backflow and pollution of the water purifier may result.

Do not block water proportioner.

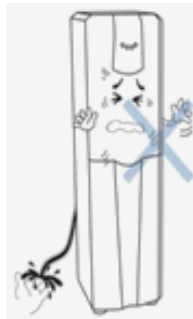

Higher TDS of produced water, RO membrane blocking or no water production may occur.

Before moving the unit, empty the water inside. Do not tip the machine beyond 45°.



This will prevent backflow of refrigeration fluid in the compressor and water tank leaks that could damage the circuit.

Place the unit on a level surface and keep the cooling fin in the back at least 10cm from walls or other objects.

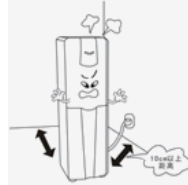

This will facilitate the release of heat.

Feed water should be municipal tap water and cannot exceed 38°C.



If the inlet water exceeds 38°C, damage to the RO membrane and membrane failure may result.

Don't place the unit in a place where temperature is below 5°C.



When ambient temperature is below 5°C, make sure anti-freezing measures, such as turning on the heat or air conditioner, should be adopted. Otherwise, water freezes in the machine due to low temperature. As a result, pipe cracking, water or electricity leakage might occur.

Don't put it in direct sunshine.



Microorganism breeding, water quality decrease, pollution of internal components may occur.

Don't store or operate the water purifier outdoors.



Accelerated aging of the water purifier pipes and parts may result, leading to leakage or machine failure.

NOTES

Please replace filters regularly. Disconnect water source and power immediately and call our hot line .

- Any parts or pipes leak.
- Any parts of the system malfunction.
- Any strange phenomena or malfunctions occur.

Product Introduction

1.Product Appearance

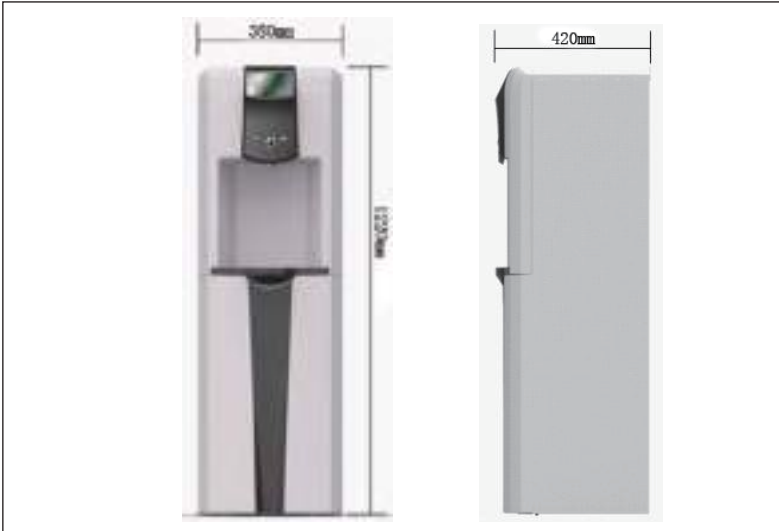

2.Technical Specifications

Model	ADR75-V-ET-1
Function	<input checked="" type="checkbox"/> Heating <input checked="" type="checkbox"/> Refrigerating <input checked="" type="checkbox"/> Normal temperature
Voltage	AC 220V 50Hz
Heating /Cooling/Gross power	500W/85W/630W
Suitable water pressure	0.1MPa~0.35MPa
Feed water temperature	5~38°C
Max. feed water TDS	≤1000PPM
RO Membrane	75GPD
Quality of produced water	Accord with requirements of Sanitary Standard for Hygienic Safety and Function Evaluation on Treatment Devices of Drinking Water——reverse osmosis Treatment Device.
Execution standard code	Q/3200 AONJ 007-2012
Health Permit Document No.	Wei Shui Zi (2010) No.0092
Purified water flow	0.15L/min
Flush Method	Auto flush
Electric shock protection type	Type I
Electric shock protection type	Municipal tap water, accord with GB5749
L*W*H (mm)	380×420×1220

Note: the above-mentioned specifications may change due to product update, and the specifications shall be subject to the nameplate.

The purified water flow is tested under environmental temperature of $25\text{ }^{\circ}\text{C}\pm 2\text{ }^{\circ}\text{C}$ and water temperature $25\text{ }^{\circ}\text{C}\pm 1\text{ }^{\circ}\text{C}$.

3. Structural Drawing

Diagram 1

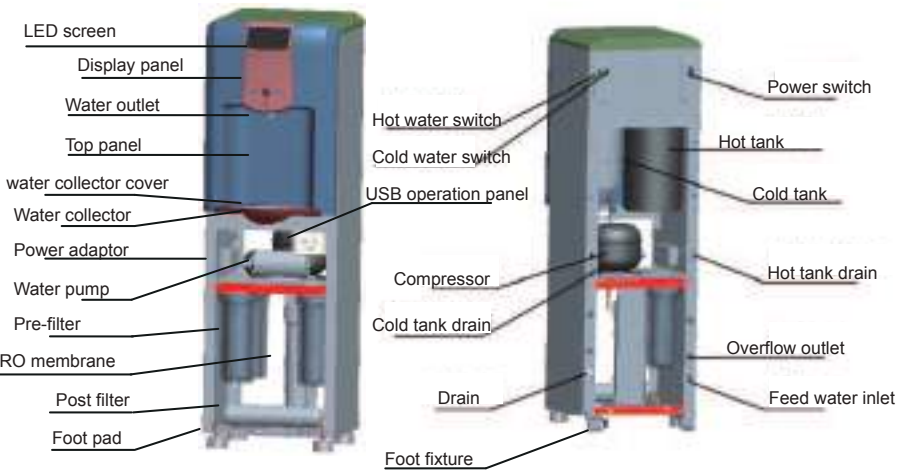

4. Electrical Circuit Diagram

Diagram 2

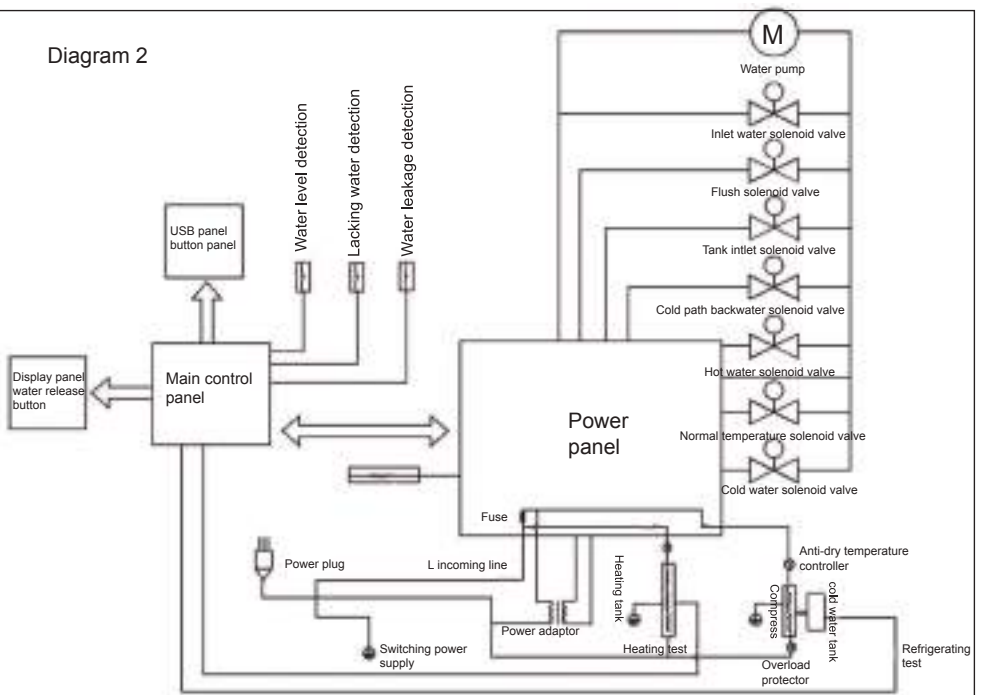

5. Water Flow Diagram

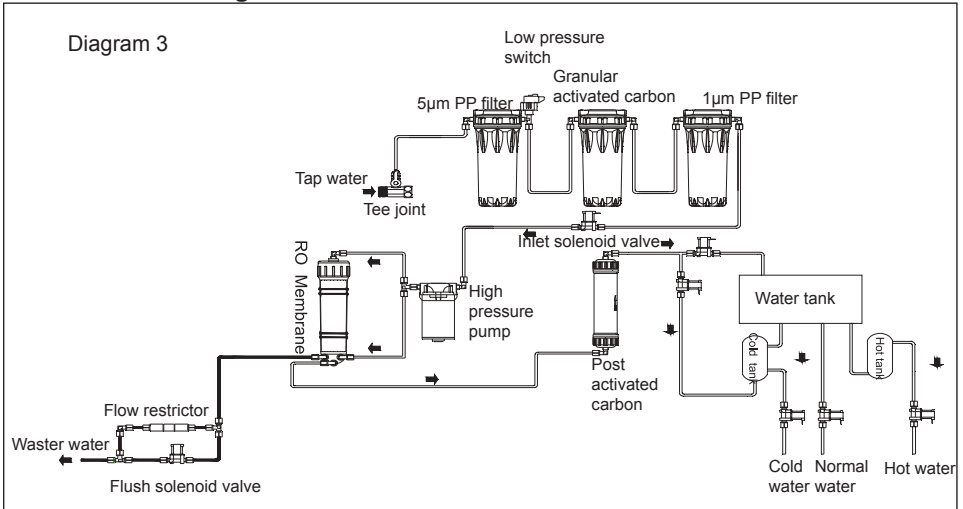

6. Function Introduction

(1) Panel button function



Hot water button: Push this button to release hot water. Press it again, then stop producing water.

Note: Hot water button is only effective when child lock indicator is off.

Room temperature water button: Push this button to release room temperature water. Press it again, then stop producing water.

cold water button: Push this button to release cold water. Press it again, then stop producing water.



Child lock button: Hold this button for 3 seconds to switch between locked and unlocked. The default status is unlocked.

Note: Pressing hot water button/ room temperature button can get corresponding water (can only choose one type). Push it again, then former operation is cancelled. if water is released for 1 min, system will implement automatic water break protection.

(2) LED Screen Function







1) Power On: display in full screen for 5 seconds and twinkle for 3 times, then the unit enters into initialized state.

2) Produce water: if water grid on  flashes from top to below and indicator on icon  keeps on, it shows that product is purify water. Otherwise, system is not working.

3) Water level: three lines on  represent different water levels of water tank. One line indicates low water lever. Two lines represent medium water level while three lines mean the tank is full.

4) Lack water: All water grids on  light off.

5) heating:  -heating,  - heating standby.  icon turns off when heating system is closed.



6) refrigerating:  -refrigerating.  -refrigerating standby.  icon turns off when refrigerating system is closed.

7) child lock icon: stays on when it is locked.(hot water button becomes invalid). Turns off when it is unlocked. (hot water button becomes effective.)

8) water temperature: hot water temperature:  red, real-time display of water temperature in the tank.

9) filter life:  Use different colors to show the status of filter in corresponding stage. Green: normal state. Red: filter needs to be replaced immediately. Orange: early warning, filter needs to be replaced after some time (please call our hot line and prepare for machine maintenance)

2. Alarming function: After buzzer makes alarm, alarming code displays on  and the whole screen flashes. (please call our hot line and prepare for machine maintenance)

1) filter life alarm: The icon  turns red when corresponding filter is reaching the end of its life. And it turns orange to make early warning. Early warning: alarm buzzes 4 times when entering into water production state. It will make the second warning after 24 hours. Alarming: alarm buzzes 8 times when entering into water production state and F1 shows on .

2) water leakage alarm: F2 shows on  and alarm keeps buzzing.

3) overflow alarm: F3 shows on . Alarm buzzes 3 times with 2 seconds as a cycle.

4) super high temperature alarm: F5 appears on . Alarm buzzes 5 times with 2 seconds as a cycle.

5) Ultra low temperature alarm: F6 appears on . Alarm buzzes 6 times with 2 seconds as a cycle.

6) Lacking water alarm: F7 appears on . Alarm buzzes 7 times with 2 seconds as a cycle.

7) Hot water NTC failure: E1 appears on . Hot water NTC is short circuited, open circuited or the unit doesn't stop working after heating for 45mins.

8) cold water NTC failure: E2 appears on . Cold water NTC is short circuited or open circuited.

9) High and low floater failure: E4 shows on , high and low floater is abnormal.

machine maintenance)

(3) USB panel Function

"Select" button: can select 1st, 2nd, 3rd, 4th, 5th stage filter. Corresponding icon stays on.

"Reset" button: Hold it for over 3 seconds to activate it. Reset selected filter life and corresponding filter indicator flashes in green. Do nothing for 10 seconds to exit this status.



Note: reset button can only be operated when replacing filter, otherwise, it is not permitted.

(4) Our primary water quality treatment components adopt the most advanced RO technology in the world. Please find below their configurations.

Stage	Product type and material	Function
1st stage	5µm PP filter	The PP filter has a 5 micron pore size that can effectively filter rust, sand, other solid impurities, and larger particles in water.
2nd stage	Granular activated carbon filter	The carbon filter can effectively adsorb free chlorine, organic matter, disinfection byproducts, smells, discoloration, and other substances in water.
3rd stage	1µm PP filter	The 1-micron PP filter can further remove particles of a smaller size, such as suspended solids and colloids.
4th stage	Reverse osmosis membrane	Effectively remove bacteria, viruses, heavy metals, pesticide residues, and other harmful substances from the water
5th stage	Post activated carbon filter	Removes odor and adjusts taste.

(5) ON/OFF function: Turn off " power switch" to cut off power of the whole unit. Turn off " hot water switch" to stop heating function. Users can choose ON/OFF according to different needs.

(6) Foot pad function: There are four foot pads at the bottom of this machine to adjust stability when ground is un-level.

How to Install

The company recommends professionals install the machine for you because the product needs to be installed and adjusted according to on-site situations of the user.

1. Pre-Installation Preparations

- 1) Confirm the location where the water purifier will be installed.
- 2) Confirm that you have the various tools required for installation.

Monkey wrench	1 piece
Electric drill	1 piece
6.2mm drill	1 piece (drain hole)
Philips and flathead screw driver	1 piece for each
Scissors	1 piece
14-16mm wrench	1 piece
19-21mm wrench	1 piece
Nipple pliers	1 piece

- 3) Confirm that you have all of the accessories required for installation
- 4) Prior to installation, turn off the water and electricity

2. Instructions for Proper Installation

- 1) How to install inlet metal hose and tee joint

Turn off tap water valve and unscrew end cap of water pipe. Take tee joint out of accessory box and wrap its male thread with Teflon tape. Then screw the tee joint into water pipe. At last, wrap the male thread of end cap with Teflon tape and screw it into the other end of tee joint. (see diagram 6)

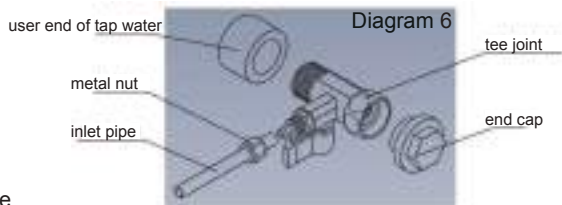

- 2) How to install water inlet pipe

Take the 1/4" water pipe out of accessory box and cut a suitable length of water pipe. Connect one end of water pipe with the inlet of tee joint (refer to Diagram 6) and screw the metal nut to right position; connect the other end of water pipe with the inlet interface on the back of the machine. Please be noted that the water pipe shall be plugged in and match with the quick joint properly to prevent tube burst and water leakage.

3) How to install waste water pipe and overflow pipe

Take out two suitable lengths of 1/4" water pipe and connect them with the wastewater outlet and overflow outlet at the back of the machine. Use a $\phi 6\text{mm}$ drill to punch two small holes into the sink drain pipe. Place the other ends of the wastewater pipe and overflow pipe just inside the holes. Put some silica gel where the 6mm pipes and the drain pipe connect to prevent leakage and use a cable tie to attach the wastewater pipe and overflow pipe to the drain pipe.



Notice: The highest point of overflow water pipe cannot be higher than overflow outlet. Otherwise, water is not able to flow down.

4) How to install filter

First, take out water collector and remove two screws. Press plastic padlock and dismantle panel of the unit. Unscrew the 1st, 2nd and 3rd filter cartridges from air purifier interior, and install corresponding dense filter cotton and pre-carbon filter. When the 2nd activated carbon filter is used for the first time, some activated carbon powder from the activated carbon filter will flow into the 3rd stage dense cotton filter or even RO membrane, resulting in filter and membrane component damage. So before installing dense filter cotton, place a bigger container in the installation place of the 3rd stage filter cartridge, then turn on inlet valve and switch, power on and flush pre-activated carbon. When there is no black water coming out, turn off power switch and install dense filter cotton into the 3rd stage filter cartridge. (see Diagram 7)



Diagram 7



Notice : Use a bigger container to hold water before installing the 3rd stage super dense filter cotton. Install the 3rd stage filter until there is no black water coming out.

5) How to install RO membrane

Take the water inlet pipe from the quick joint of membrane housing and unscrew the membrane housing with its wrench. Then take RO membrane out of vacuum package and install the end with four O rings into membrane housing tightly (see Diagram 8), in the end install the housing cover and tighten it with cover wrench. Reconnect the water inlet pipe into the quick joint of membrane housing and then lock the membrane housing clip into the large single clip.



Warning:

- ◆ Pay attention to RO membrane direction during installation;
- ◆ Check whether one end of the membrane has 4 O rings or not when installing RO membrane.
- ◆ If it is installed properly, RO membrane can be installed into membrane housing easily. if it is difficult for membrane to install into it, don't insert RO membrane into membrane housing violently which might cause permanent damage to membrane housing and membrane element (The manufacturer is not liable for any damage to membrane caused by improper installation);
- ◆ Damage to membrane housing and RO membrane caused by above-mentioned reasons is not included in the warranty scope.

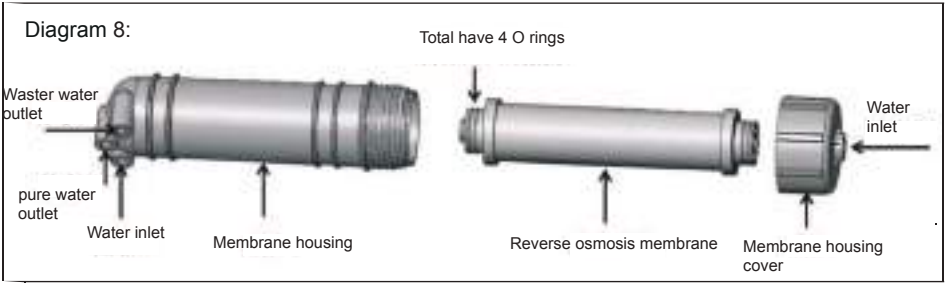

6) How to install foot fixture

Remove screws at the bottom of machine back. Take foot fixture out of accessory bag and fix it on the machine. Then screw on and Fix it on the floor with plastic expansion screw (See Diagram 9)

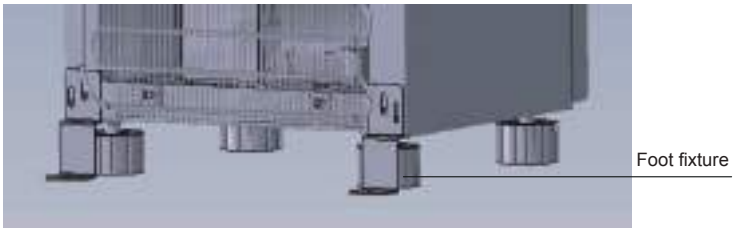
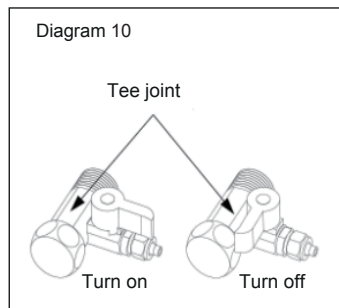

Diagram 9

Adjustment Procedures

Please confirm whether water pipe is connected properly and whether there is water/ power supply. Please confirm whether water pipe is connected properly and whether there is water/ power supply. Then follow below adjustment procedures.

- 1) To prevent some activated carbon from entering into pure water tank when post activated carbon is used for the first time, after finishing the installation of filter and RO membrane, cut off a certain length of 1/4" water pipe and connect it into outlet end of post activated carbon. Then turn on inlet valve and inlet switch (Diagram 10) and switch the power on. Flush RO membrane and post activated carbon for 15mins and connect it to former 1/4" pipe. Continue to product water. When water production stops, turn on hot water switch. Press room temperature water button and hot water button to release corresponding water.



- 2) Check whether connection between joints are reliable and if there is any water/electric leakage phenomenon on the joints of membrane housing and filters.
- 3) When the unit stops producing water, check whether water drainage stops.
- 4) Turn off hot water switch. Then check whether heating function stops.
- 5) Turn off power switch. Then check whether the whole unit powers off.

Operating Instructions

- 1) Please often observe the completion of whole unit to ensure safe use. When you will not use the machine for an extended period of time, disconnect water and power source to avoid microbial breeding. Remove screws and drain block plate with Philips screwdriver. Unscrew nut of hot tank outlet and take down drain plug(refer to Diagram 11). Drain water out of hot tank and restore drain plug, drain nut and block plate to the former position.



Note: Prevent burns when draining hot water out.

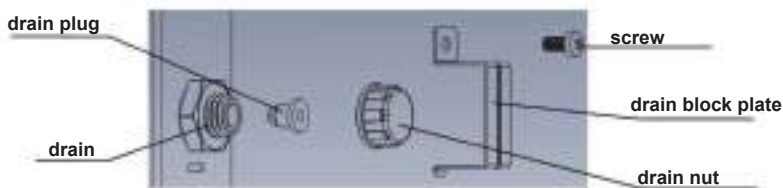

Diagram 11

- 2) When you use the machine again, turn on inlet valve and inlet switch. After make sure that there is no water leakage, turn on power switch. When the unit stops producing water, switch hot water on.
- 3) The 'Operating' in this 'Operating Instructions' means turning on power supply and/or opening inlet valve to make the water purifier under working conditions.

Maintenance & Upkeep

1. Filter Life

- 1) This machine has the function of automatic filter replacement reminder. (Please see page 12) The recommended filter life is based on the average indexes of tap water in various districts. If users' actual water quality and using frequency have a great discrepancy with average index, actual filter life differs greatly from estimated time, such as early clogging or invalidity of filters. The customer should arrange for replacement with their local service center based on the machine's actual usage conditions.

- 2) The estimated filter life of this purifier is calculated based on household use. Please do not use this purifier in a public place with much higher water consumption. In those cases, we recommend that you choose our commercial model.
- 3) Based on the assumption that the feed water is municipal water and daily water consumption is 12.5L, the suggested filter life is as follows(below data is for reference only):

Stage	Period
1st stage: 5µm PP filter	12 months
2nd stage: Granular activated carbon filter	24 months
3rd stage: 1µm PP filter	24 months
4th stage: Reverse osmosis membrane	36 months
5th stage: Post activated carbon filter	12 months

Note: Since water quality exerts great influence upon filter life, and RO membrane life is also affected by various factors, filter life might be higher or lower than above-mentioned in reality, and thus above data is only for reference. The customer should consider replacing filters under below circumstances:

- ◆ The taste of the pure water is bad and the TDS value has increased.
- ◆ The pure water flow has decreased. Check whether the filters or membrane are blocked (make sure it is not because of low inlet water temperature).
- ◆ The filter is covered by mud or its color has changed.
- ◆ No pure water comes out of the water purifier.

2.How to Replace

Please call our hot line for filter replacement. After-sales service staff will help you replace filter to avoid misoperation. The manufacturer is not liable for any losses caused by improper operation, or operation not following instruction.

- 1) Replacement of the 1st and 3rd stage filter cotton and the 2nd stage front activated carbon
 Firstly turnoff water inlet valve and unscrew corresponding filter cartridge with filter cartridge wrench. Take out old filter and place new filters into the filter cartridges (note: dense filter cotton is installed in the 1st filter cartridge; front activated carbon is installed in the 2nd stage filter cartridge and the end with silicone cushion shall be upward; super dense filter cotton is installed in the 3rd stage filter cartridge). Then tighten cartridge cover with wrench. Before front activated carbon filter is replaced, flush it firstly to prevent activated carbon powder from entering into the 3rd stage filter or RO membrane, which will damage filter and membrane elements. The detailed operation procedures are as follows:
 - (1) Turn off inlet switch of water purifier.
 - (2) Remove the 3rd stage cartridge with cartridge wrench;
 - (3) Collect water at the 3rd stage filter cartridge cover with a big container;
 - (4) Turn on inlet switch and wait until the outlet water from the 2nd filter is not black anymore;
 - (5) Turn off inlet switch, place the filter into filter cartridge and then tighten the 3rd stage filter cartridge cover.

Note: when the machine is restarted after filter replacement, the machine will alarm shortly for water shortage. However, this is completely normal because the machine hasn't been filled with water yet. It will stop alarming and return to normal quickly.

2) Please refer to " How to Install RO Membrane" (page 16) for replacement of the 4th stage RO Membrane.

3) Replacement of the 5th stage post activated carbon

Firstly, turn off inlet switch and take out the water pipes on the two sides of the post activated carbon to be replaced. Get a new filter and install it according to original water inlet and outlet direction. Turn on inlet switch and the unit starts producing water normally. Yet produced water can't be used until the new post activated carbon is flushed for 15 minutes.

3. Notes

1) Water output of RO membrane

Water output of RO membrane is subject to inlet pressure and inlet temperature. Nominal 75GPD of this machine is tested when the net pressure before RO membrane is 0.5MPa and inlet water temperature is 25 C . If net pressure is less than 0.5MPa or water inlet temperature is lower than 25 C , water output of RO membrane will be less than 75GPD. The rated gross pure water output is 1000L (Tested according to requirements of Sanitary Standard for Hygienic Safety and Function Evaluation on Treatment Devices of Drinking Water—Reverse Osmosis Treatment Device.)

2) Treatment of old filter

The replaced old filter can't be cleaned or recycled. So it is recommended that old filter shall be abandoned as solid household garbage and treated by professionals.

3) When you will not use the machine for an extended period of time, disconnect the water and power source of water purifier.

4) When any of the following situations occur, immediately disconnect the water source (and/or the power source from the purifier and call our national hot line.

- ◆ If the water purifier pipes or related components are leaking.
- ◆ If the water purifier's related components stop working.
- ◆ If electricity leaks from any components.
- ◆ if water leakage protector makes alarm. (See Diagram 12)
- ◆ If there are any other anomalies or failures.



Diagram 12

◆ If related component of the water purifier is damaged, please contact with national service hot line and our after-sale service staff will replace it for you to avoid damage. Our company is not liable for any loss caused by operation not following this user manual.

Trouble shooting

Failure	Possible Cause	Resolution Method
The machine can't be started.	Power supply is not connected	Check power supply or power supply socket
	low feed water pressure or no water supply	Check feed water pressure.
	Low pressure switch fails. Power supply cannot be connected.	Measure resistance after feed water is connected. Replace low pressure switch.
	High pressure switch can't reset	Measure resistance after decompression. Replace high pressure switch.
	Power switch is burned out	Measure output voltage, replace power switch.
Refrigerating fails	No output voltage from control unit	Measure output voltage, replace control unit.
	Refrigerating system is not powered on	Power on and turn on cold tank rocker switch
	No water or low-level water in pure water tank	wait till water level in pure water tank meets the requirement
	Compressor failure	Change compressor
The machine keeps powering on and off repeatedly after standby	Refrigerant leakage	Refill refrigerant and check the tightness of refrigeration system
	Machine vibrates. water level in the tank is not stable. High and low level float fails.	Operate the machine after placing it in
	High and low level float failure	Replace high and low level float
	Hot water temperature sensor failure	Replace hot water temperature sensor
Small or no pure water output	Cold water temperature sensor failure	Replace cold water temperature
	Filter blocking	Replace filter
	RO membrane blocking	Replace RO membrane
	Inlet solenoid valve failure	Replace inlet solenoid valve
	Check valve blocking	Replace check valve
The high pressure pump works normally but no water is produced	Lack of pressure in high pressure pump	Measure pump's outlet pressure. Replace high pressure pump.
	High pressure pump failure	Measure pump's outlet pressure. Replace pump.
	Inlet solenoid valve fail to open (no pure water or wastewater)	Replace inlet solenoid valve
	Pre-filter blocking	Observe pure water and wastewater flow. Replace pre-filter.
	RO membrane blocking	Replace RO membrane
System stops but waste water doesn't stop	Control box failure. Can not turn off flush solenoid valve.	Check whether there is input voltage. Replace control box.
	Inlet solenoid valve fails. Can not stop water flow.	Observe waste water. Replace inlet solenoid valve
	Decompression of check valve (small flow of waste water)	Observe waste water and replace check valve.
Heating fails	Heating system is not powered on.	Power on and turn on hot tank rocker switch
	No water or low-level water in pure water tank	Wait till water level in the water tank meets the requirement.
	Heating rod failure	Replace hot tank

Package Contents

Machine (including RO membrane)	1 set
Three filter cartridges and three filters	1 set
2' water pipe	1 roll
3' water pipe	1 roll
Gooseneck faucet	1 piece
Filter cartridge wrench	1 piece
Membrane housing wrench	1 piece
User manual	1 piece
Silicone pad and demonstration instruction	1 piece
Accessories:	1 package
Including: tee joint	1 piece
2' pipe plug	2 pieces
3' pipe plug	1 piece
3' nut	1 piece
Hangers for faucet	1 piece
waste water clip	1 piece
Teflon tape	1 roll
M5×16mm big flat head self-tapping screws	2 pieces
Nylon cable ties	5 pieces

Note:

Unit conversion:
 0.1 MPa=1.02kg/cm²=14.5 Psi
 1 Psi= 0.07Kg/cm²
 1 gallon= 3.785 Liters

Warranty Terms & Conditions

1. Warranty period

Complete machine is warranted for one year from the installation date or the date of purchase on invoice. However, consumable items are not covered by the guarantee. (Consumable items include filter and RO membrane).

2. Warranty Conditions

Users shall abide by following rules; otherwise, warranty will be void.

- 1) Users shall purchase our products from authorized retailers and through official channels.
- 2) Please keep your invoice and user manual properly, and make sure product's serial No. on user manual is in accordance with the one which can be found on the machine.
- 3) Product shall be installed by staff designated by manufacturer or qualified installer approved by national authorized organizations. (Any installation without guidance is not allowed.)
- 4) Users must follow instructions strictly.
- 5) Users shall use products in appropriate conditions.
- 6) If any maintenance or repair is needed, please dial company's hot line for repair.

3. Exceptions

The following product failure or damage is not covered in the warranty.

- 1) Obtain products in illegal ways or through unauthorized channels.
- 2) Loss of invoice, user manual or serial No. on product.
- 3) Serial No. on instruction is not in accordance with the one on product.
- 4) Any failure or damage caused by self-installation without manufacturer's guidance or qualified staff's installation.
- 5) Product misuse, or any failure or damage caused by violation of instruction.
- 6) Product failure or damage due to use beyond normal conditions
- 7) (Intentional or unintentional) damage to the machine
- 8) Damage caused by force majeure (such as natural disasters, wars)
- 9) Company is not liable for the warranty If customer doesn't call company's hot line for repair, or product has been repaired by unauthorized staff.

4. Warranty Service

As for any product failure of damage in accordance with warranty conditions during warranty period, and without violating exceptions, company will provide all-around warranty service, which includes:

- 1) Repair of damaged machine for free.
- 2) Replace damaged parts for free
- 3) Other items regulated by national laws (including Law on Protection of the Rights and Interests of Consumers)

5. Warranty Service Procedures

- 1) Please turn off water valve or cut off power immediately after discovering fault phenomenon when using our products. After confirming that all meet warranty conditions, please dial our company's hot line for timely repair.
- 2) Please show maintenance staff valid invoice and report use & failure situation. After checking the machine, service staff will do the maintenance.
- 3) When service is finished, customer makes comments on Service Order and sign name. If any doubt, please enquire service staff promptly.
- 4) If damage is not covered in warranty, user should pay service charge according to charging standard shown by service staff.
- 5) If users have any objections or questions to service procedures, please dial our company's hot line for consultation.

Our company's 8h00 -17h00pm hot line 1900 XXXXXX

Warranty card

Model

ADR75-V-ET-1

PURCHASER INFORMATION

PURCHASER'S NAME

ADDRESS

CITY

MODEL NO.

SERIAL NO.

DATE OF PURCHASE

INVOICE NO.

Hotline

1900XXXX



A.O. Smith Vietnam
16 Ly Dao Thanh Street, Hoan Kiem Distric,
Ha Noi, Viet Nam.