

## SPECIFICATIONS

MODEL	HPW-60	HPW-80
Rated volume [L]	60	80
Rated voltage [V] / Rated frequency [Hz]	220 / 50	220 / 50
Rated input power [W] / Rated current [A]		
Energy-saving mode	250 / 1.25	250 / 1.25
Electrical mode heating	3,000 / 13.7	3,000 / 13.7
Net weight [kg]	46	50
Inner tank rated pressure [MPa]	0.8	0.8
Range of water temperature [°C]	35-75	35-75
Environment range of energy-saving mode [°C]	10-43	10-43
Name of refrigerant	R134a	R134a
Refrigerant filling volume [g]	156	156
Noise level [dB [A]]	≤ 40	≤ 40

## DIMENSIONS (mm)

MODEL	HPW-60	HPW-80
L	895	1050
S	510	510
S1	250	250
S2	480	480
L1	290	335

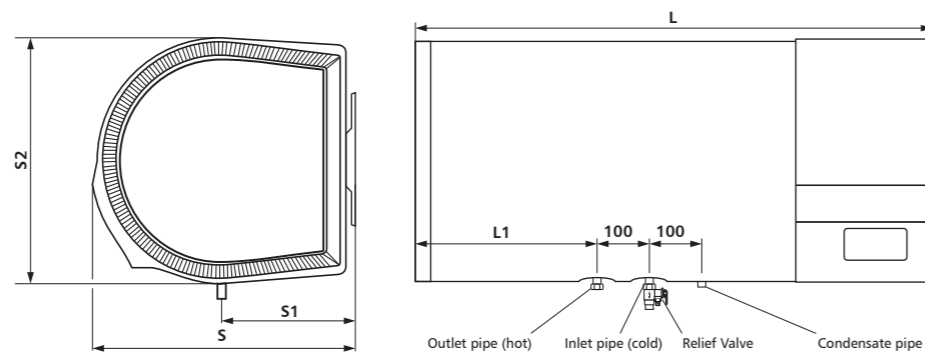

Contact your friendly A. O. Smith dealer today:



**AC Smith**  
Innovation has a name.

Website: [www.aosmithindia.com](http://www.aosmithindia.com)

### REGISTERED OFFICE:

Manufactured by **A. O. Smith India Water Products Private Limited**  
(formerly known as A. O. Smith India Water Heating Private Limited)

Plot No. 300, Phase - II, KIADB Industrial Area, Harohalli, Kanakapura Taluk, Ramanagara District, Karnataka – 562 112, India.  
CIN: U31909KA2006PTC040282

### REGIONAL OFFICES:

#### CHENNAI:

No: 267, Second Floor,  
Kilpauk Garden Road,  
Kilpauk,  
Chennai – 600010, India.

#### DELHI:

A-283, 2nd Floor,  
Phase-1  
Okhla industrial Area,  
New Delhi – 110 020, India.

#### KOLKATA:

224 A, Office No. 811,  
8th Floor, Krishna Building,  
AJC Bose Road,  
Kolkata – 700 017, India.

#### PUNE:

Soharab Hall, Office no. 125  
& 126, 1st floor, Opp.  
Jahangir Hospital, Tadiwala  
Road, Pune - 411 001.

# Air2Heat Water Heaters.

## Generates heat from air. Saves up to 60%<sup>†</sup> on electricity.



### Renewable energy water heater. Reliable and energy saving.

- A. O. Smith Air2Heat water heater is an advanced and innovative product that generates heat from the environment. It is a clean and efficient use of free energy source to provide hot water.
- A. O. Smith Air2Heat water heater uses very little energy. For each unit of electricity consumed, it generates 2.3 units of heat energy. Saves up to 60% of electricity compared to electric water heaters.
- Based on reliable and well proven technology, A. O. Smith Air2Heat water heaters work all year round, day and night, and are more convenient and more reliable than Solar water heaters.
- A. O. Smith Air2Heat water heater has in-built intelligent functions and all operations are automatic.
- A. O. Smith Air2Heat water heater is available in large 60 & 80 litre capacities, and a single installation can provide hot water to two-three bathrooms.



\* Featured model is available in 60 & 80 litre capacities.  
<sup>†</sup> Compared to an electric water heater.

**AC Smith**  
Innovation has a name.



## INTRODUCTION

### Advanced and Innovative Product that Generates Heat from the Environment

- A. O. Smith Air2Heat water heater is an advanced and innovative product that generates heat from the environment. It uses electricity to move heat from one place to another instead of using electricity to heat the water. It therefore uses very little energy.
- A. O. Smith Air2Heat water heater moves [pumps] some of this heat from outside to provide hot water inside. To move the heat, the A. O. Smith Air2Heat water heater works like a refrigerator in reverse. While a refrigerator pulls heat from inside the refrigerator and transfers it into the surrounding room, the A. O. Smith Air2Heat water heater pulls heat from the surrounding air and transfers it into a tank to heat water.

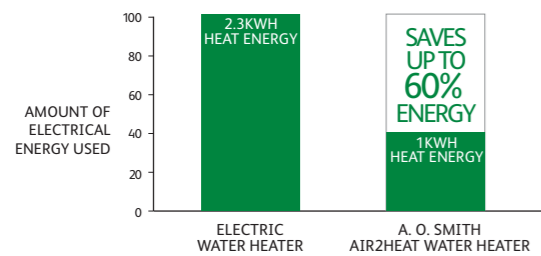
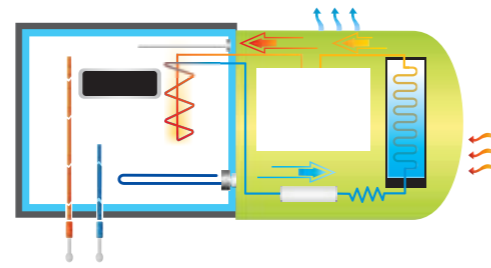

### Provides 2.3 times more Energy than it uses

- A. O. Smith Air2Heat water heater is a high efficiency device that can provide up to 2.3 kWh of heat energy by using 1 kWh of electrical energy.
- It can generate the same amount of heat energy as an electric water heater by using only 40% of the energy. With the A. O. Smith Air2Heat water heater, you can save up to 60% of electricity compared to electric water heaters.

### Installation Requirements

- While the A. O. Smith Air2Heat water heater is a compact water heater that occupies about 0.219 cubic metres [7.8 cubic feet] volume and can be wall mounted, for effective and efficient functioning, it needs to be installed in an enclosed area of at least 100 cubic feet.
- However, if the installation area is open to air, there is no minimum space requirement.

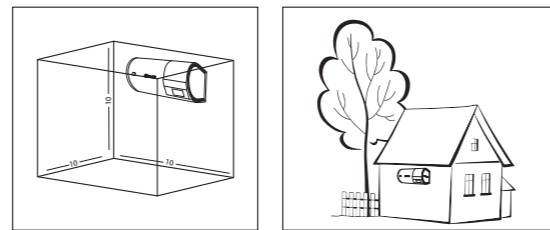

### Intelligent & Automatic Operations

- A. O. Smith Air2Heat water heater has in-built intelligent functions and all operations are automatic.
- A. O. Smith Air2Heat water heater is available in large 60 & 80 litre capacities, and a single installation can provide hot water to two-three bathrooms.
- A. O. Smith Air2Heat water heater has very few rotatory components. This reduces maintenance requirements. Built to last, it has an attractive and high-quality finish.

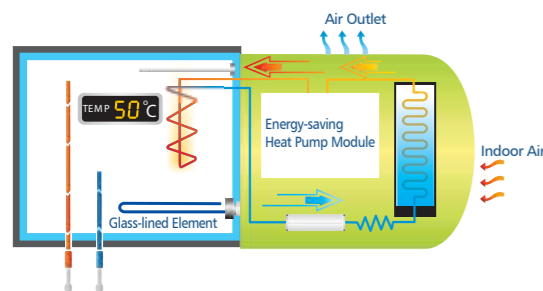

### A. O. Smith: A History of Innovation

- A. O. Smith Corporation is the largest water heater manufacturers in North America and a global leader in innovative technology and energy efficient solutions. Founded in 1874, A. O. Smith are the inventors and developers of the patented process to glass-line water heaters. Over the years, A. O. Smith has gained the respect and support of homeowners, contractors, architects and specifying engineers in over 60 countries by providing innovative energy efficient products designed for years of trouble-free service.



## BETTER TECHNOLOGY, BETTER QUALITY, BETTER FEATURES

### Wired Remote

- A. O. Smith Air2Heat water heater comes with a wired remote.
- Users can access various settings through the remote control.
- Solar water heaters typically do not have remote control functions.

### Intelligent Electronics

- A. O. Smith Air2Heat water heater uses a digital temperature controller which is highly reliable.
- A. O. Smith Air2Heat water heater have the electronic diagnostic features which help pinpoint problems like improper supply voltage, etc.
- Solar water heaters typically have mechanically operated thermostats and cut-outs which are less reliable and prone to false thermal cut-out tripping.
- Solar water heaters typically do not have diagnostic features.

### Superior Quality

- A. O. Smith Air2Heat water heater has superior, high quality Glass Lined tanks and Heat Exchanger.
- Solar water heaters typically have stainless steel tanks which are prone to rust and leakages.

### Aesthetics

- A. O. Smith Air2Heat water heater are designed and manufactured by A. O. Smith, North America's largest manufacturer of water heaters.
- Typical Solar water heaters are not very elegant and usually made by small and local manufacturers.

## COMPARISON: ELECTRIC WATER HEATERS AND PAYBACK CALCULATORS

- A. O. Smith Air2Heat water heater saves up to 60% on electricity costs compared to electric water heaters.
- Your savings on electricity cost will depend on usage and hours of operation. The table below would give you an idea of what a typical installation, which uses 60 and 80 litres of water daily, will save you.

PARTICULARS		COMPARED WITH HPW-60	COMPARED WITH HPW-80
Hot Water Used Daily	Hot Water Used Daily [Litres]	60	80
	Initial Water Temperature [°C]	20	
	Average Output Water Temperature [°C]	50	
A. O. Smith Air2Heat Water Heater	Energy Consumption [kWh]	0.88	1.13
	Cost in INR at ₹ 5 per kWh	4.38	5.63
Electrical Water Heater	Energy Consumption [kWh]	2.30	3.07
	Cost in INR at ₹ 5 per kWh	11.52	15.36
Cost Savings [ ₹ ]	Per Day	7	10
	Per Month	214	292
	Annually	2,608	3,553

## KEY FEATURES

### EFFECTIVE AND EFFICIENT

A. O. Smith Air2Heat water heater effectively and efficiently uses thermal energy from the environment to heat water.

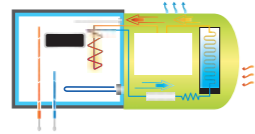

### ENERGY SAVING

A. O. Smith Air2Heat water heater is highly efficient, energy saving and environment-friendly device. While running in energy saving mode\*, users can save up to 60% on electricity cost; when compared to a conventional electric water heater.

60%

\*when set to 50°C temperature & under standard test conditions

### DIGITAL DISPLAY

A. O. Smith Air2Heat water heater has a built-in digital display for readings and for key parameters ease of operations.

The user definable functions and parameters are setting of Mode, Timers, Override, AES [Adaptive Energy Saving System], Temperature Setting, Hot Water Display Quantity and Power-off Memory Function.

The diagnostics of the unit's malfunctions can be shown by the LED display.



### WARRANTY

A. O. Smith Air2Heat water heater uses international quality compressors and high quality accessories and materials. With our careful manufacturing and strict quality control, we assure you the best quality and long life which is backed by 7 years warranty on the tank and 2 years warranty on the whole unit.

7  
Years

## INTELLIGENT CONTROL FEATURES

### AES [ADAPTIVE ENERGY-SAVING SYSTEM] FUNCTION

A. O. Smith Air2Heat water heater has unique AES feature which adopts the heating cycles to the water utilisation habit of the user. This enables water heater to switch on automatically at required time, saving energy by minimising thermal losses.



### DISPLAY OF HOT WATER AMOUNT

A. O. Smith Air2Heat water heater has a function of displaying the amount of hot water available.



### USER SETTINGS

A. O. Smith Air2Heat water heater can be set by the user to operate in different energy modes:

- The high efficiency mode uses only environmental heat to heat the water up to 50°C.
- The hybrid mode uses the heating element only if the set temperature is > 50°C.
- The electric mode in which the heating element directly heats the water.



### POWER-OFF MEMORY FUNCTION

A. O. Smith Air2Heat water heater can retain the set information for 48 hours, even in power off condition.



### INSTANT

Users can select electric heating by pressing 'override' key and Air2Heat starts electrical heating immediately to reach the pre-set temperature.



### AUTOMATED FUNCTIONS

A. O. Smith Air2Heat water heater has automated functions that monitors several critical functions and adjusts operations to maximise performance and reliability.



### PROGRAMMABLE TIMER

A. O. Smith Air2Heat water heater timer enables the unit to switch on automatically at pre-set times of the day, in energy-saving mode.

## GLASS LINED TANK



### GLASS LINED TANK

A. O. Smith Air2Heat water heater comes with a special glass lined tank. This lining offers the protection against tank corrosion and increases life of the water heater & it is achieved through a specialised fusion process. The tanks are designed to pass 1,00,000 cycle fatigue test. This makes it one of the best tanks resistant to rust and scaling.



### GLASS LINED HEAT EXCHANGER

Glass Lining of the heat exchanger offers protection against corrosion and increases life of the water heater. The lining is stronger and more corrosion-resistant than any other in the industry.

## OTHER FEATURES



### COMPRESSOR

The compressor in the A. O. Smith Air2Heat water heater is an industry leader for performance and durability.



### ANODE PROTECTION

A strong steel core anode rod is used for protecting the water tank. It greatly prolongs the service life of the A. O. Smith Air2Heat water heater.



### ENVIRONMENT-FRIENDLY REFRIGERANT

The R134a refrigerant used in the A. O. Smith Air2Heat water heater is environment-friendly.



### HIGH EFFICIENCY ENERGY-SAVING THERMAL INSULATING LAYER

A polyurethane foam insulating layer is used, which provides good insulating property and reduces heat loss effectively.



### QUIET OPERATIONS

A. O. Smith Air2Heat water heater operates at a quiet sound level of approximately 40 dBA.



### ELECTRIC HEATING ELEMENT

A. O. Smith Air2Heat water heater incorporated with a 3kW heating element which helps in quick heating. If the temperature is set above 50°C, then the heating element is activated. Users also have an option of heating the water completely in 3kW mode.

## SAFETY FEATURES



### HIGH TEMPERATURE LIMIT PROTECTION SWITCH

A. O. Smith Air2Heat water heater employs a high temperature limit protection switch. In case any fault occurs and the water temperature exceeds the highest preset temperature, then the switch rapidly cuts off the phase and neutral line simultaneously to guarantee safety.



### RELIEF VALVE

The relief valve relieves pressure automatically while the pressure in the inlet pipe exceeds the set pressure.

## WHY A. O. SMITH'S AIR2HEAT WATER HEATER IS ADVANCED AND BETTER THAN SOLAR WATER HEATERS?

### EASY TO INSTALL

#### Easy to install

- A. O. Smith Air2Heat water heater can be wall mounted and installed indoors in the loft area.
- A. O. Smith Air2Heat water heater have volumes as small as 0.22 cubic metres [7.7 cubic feet].
- They can be placed in enclosed spaces as small as 100 cubic feet.
- In open to air areas, there is no minimum space requirement.
- Solar water heaters typically occupy very large spaces.
- Solar water heaters require outdoor or rooftop installation.

#### Reduce plumbing costs

- A. O. Smith Air2Heat water heater require minimum plumbing as they can be easily installed in the bathroom or in the loft.
- Solar water heaters need to be installed outdoors and require extensive installation and plumbing up to the bathroom, kitchen and other points of use.

### EASY TO OPERATE AND MAINTAIN

#### Year round operations

- A. O. Smith Air2Heat water heater works 365 days.
- A. O. Smith Air2Heat water heater work any time of the day and can give you piping hot water even in the middle of the night.
- The performance of solar water heaters is seasonal.
- Solar water heaters give comparatively less hot water in monsoons and winter, which is when you need hot water the most.

#### Automatic backup

- A. O. Smith Air2Heat water heater has an advanced hybrid unit with backup electrical heating which can cater to peak hot water requirements.
- A. O. Smith Air2Heat water heater are equipped with AES [Adaptive Energy-Saving System].
- Solar water heaters cannot cater to peak loads.

#### Leakages and Wastage

- The special Glass Lined Tank of the A. O. Smith Air2Heat water heater offers the best protection against tank corrosion and increases the life of the water heater.
- A. O. Smith Air2Heat water heater can be installed in bathrooms. This eliminates long plumbing lines and associated heat losses.
- In Solar water heaters, leakages in the storage tanks are fairly common.
- Solar water heaters require long plumbing lines from the outdoor or rooftop installation to point of usage. These plumbing lines are prone to leakages and heat losses.

#### Intelligent and Automatic Features

- A. O. Smith Air2Heat water heater have intelligent and automatic features like timers. This switches on the unit automatically at the required time further minimising heat losses.
- Solar water heaters typically do not have such features.

## HOW DOES THE A. O. SMITH AIR2HEAT WATER HEATER WORK?

A. O. Smith Air2Heat water heater uses a gas refrigerant, which when compressed turns into a liquid.

